

Fact sheet **ECO-Skate** ICFXN20D

Container Load moving system, steerable, 4-load points

HTS

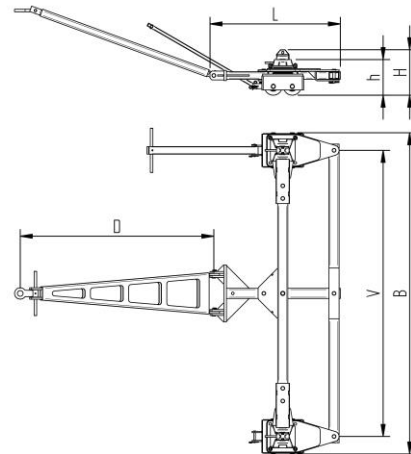

Specification:

Container transport skates for the professional indoor transport of ISO containers on clean, smooth and level floors, inc. alignment bars, flat plate with ISO container cone or container twist lock system (TLS) and high-quality HTS Nylon wheels, which are abrasion-resistant and non-marking and suitable for all smooth and level floors. In combination with an ISOCON load moving system (DUO, S, ROTO) with the same installation height, these skates form a safe system with 4 load points for ISO containers. Please note the steering angle of max. 45°. When fully utilized steering angle of the skate system, no additional steering angle of the system must be made (see operating instructions).

Technical data of load moving system:

# 10 200 03 36	Ø 0 mm	12,0 x 45 = 540 mm ² ▼ 46,3 MPa
MAT NY, 80 Shore D	L x B x H 1030 x 2537 x 282 / 359 mm	43,2 cm ²
2 x 10000 daN	D = 1620 mm V ₀ = 2259	500 daN*
2 x 4	260 kg	400 daN*

Equipped with the following wheel:

# 11 140 10 25R	12,0 x 45 = 540 mm ² ▼ 46,3 MPa
MAT NY, 80 Shore D	2500 daN
Ø140x85 - Ø30 mm	V _{max} = 2 km/h



Please always observe the operating instructions, their safety instructions and local conditions!

# Part No.	# Number of wheels	Load Area in mm	Area mm ² of the roller surface pressure ▼ N / mm ²	Traction* in daN, required force to move the load at a steady speed of 2 km/h under ideal conditions
MAT Wheel material layer, core: AL Aluminium, NY Nylon PU Polyurethane, ST Steel	Dimensions of wheel, inside ball bearing diameter mm	Dimensions in mm L x B x H	Loaded area per skate in cm ²	
Carrying Capacity of load moving skate in daN at 2km/h max.	Weight kg	Steering bar length D for L, adjustability V for S and DUO skate systems	Starting resistance* in daN, required force to start moving, under ideal conditions	* Varies depending on the tolerances of the floor and ambient situation. All information without guarantee.